

# SISTEM KOMUNIKASI OPTIK

- **BAB 1**
- **Gelombang Elektromagnetik**
  - **dan Spektrum Optik**
- **D3 Teknik Telekomunikasi – Fakultas Ilmu Terapan**



# GELOMBANG ELEKTROMAGNETIK

## APA ITU GELOMBANG ELEKTROMAGNETIK ??

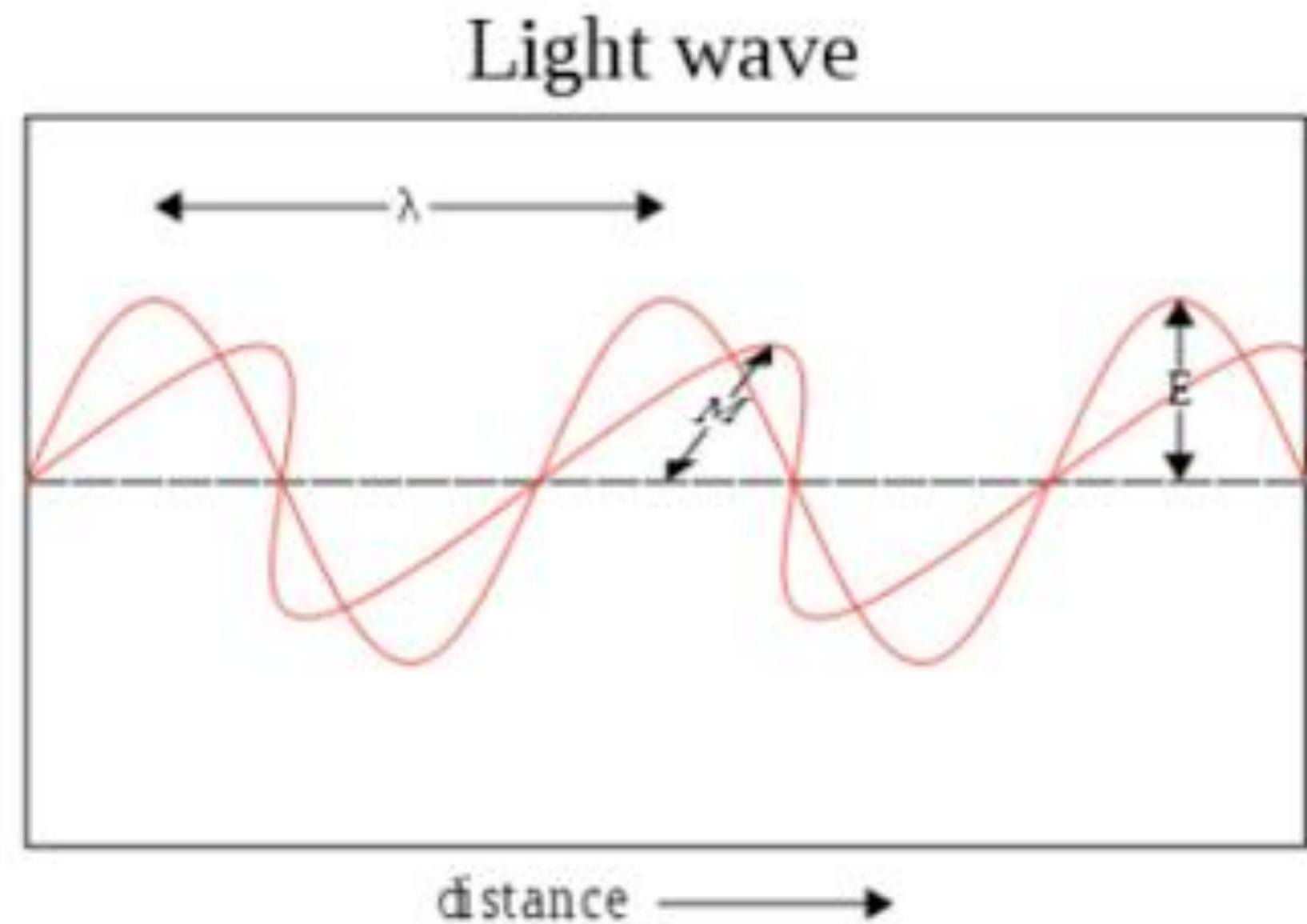

$$v = f \cdot \lambda$$

Dimana :

$v$  = kecepatan (m/s) ; diruang bebas  $v = c = 3 \times 10^8$  m/s

$f$  = Frekuensi (Hz)

$\lambda$  = panjang gelombang (nm)

# GELOMBANG ELEKTROMAGNETIK

**BAGAIMANA  
GELOMBANG  
ELEKTROMAGNETIK  
TERJADI**



HIPOTESIS

*“James Clark Maxwell“*



**“3 Fakta Relasi Antara Listrik Dan Magnet”**



# PERCOBAAN OERSTED

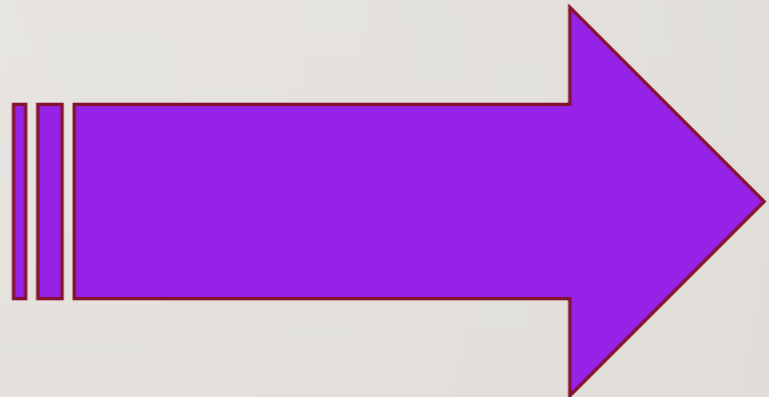
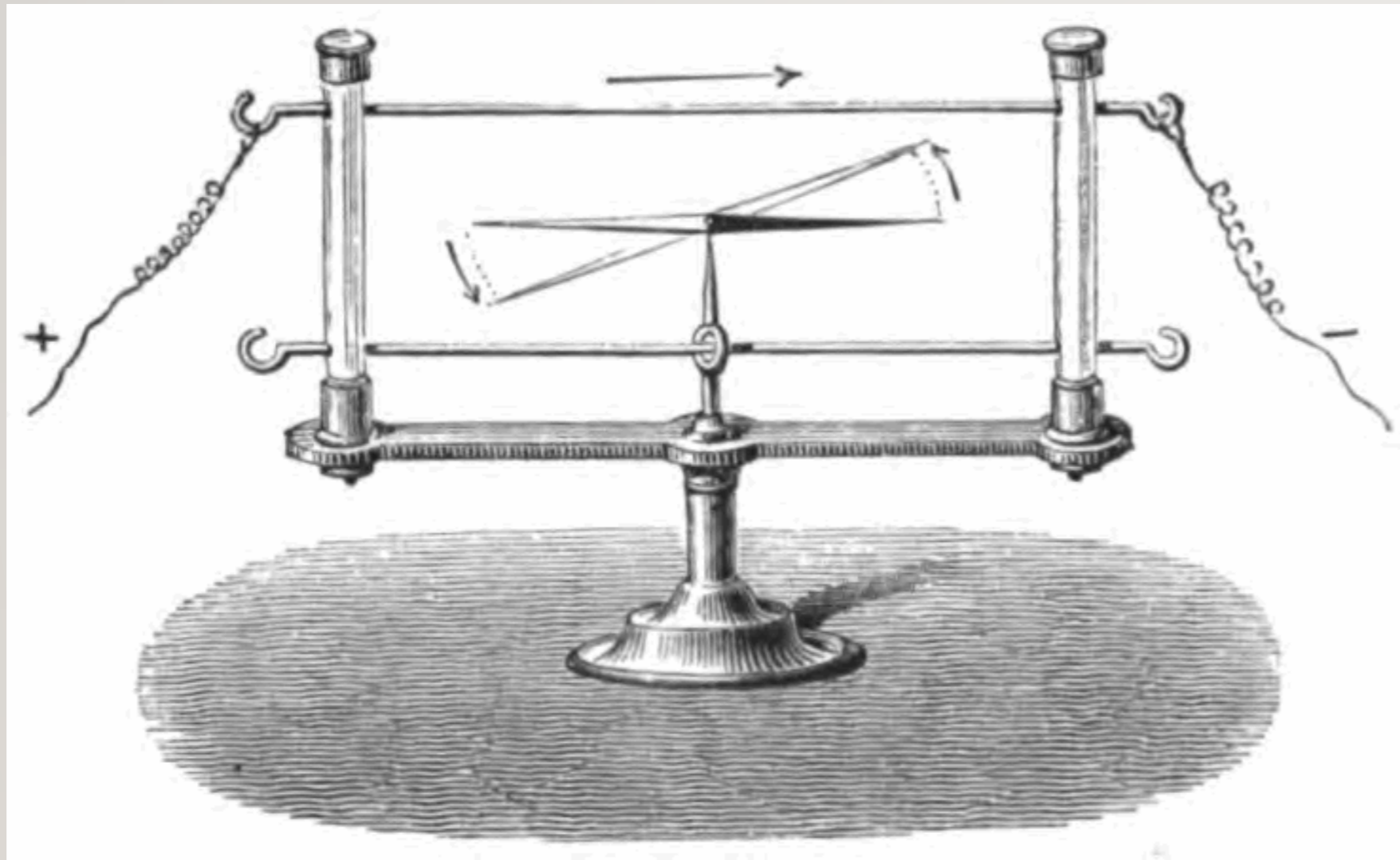

**“KOMPAS”**

# PERCOBAAN FARADAY

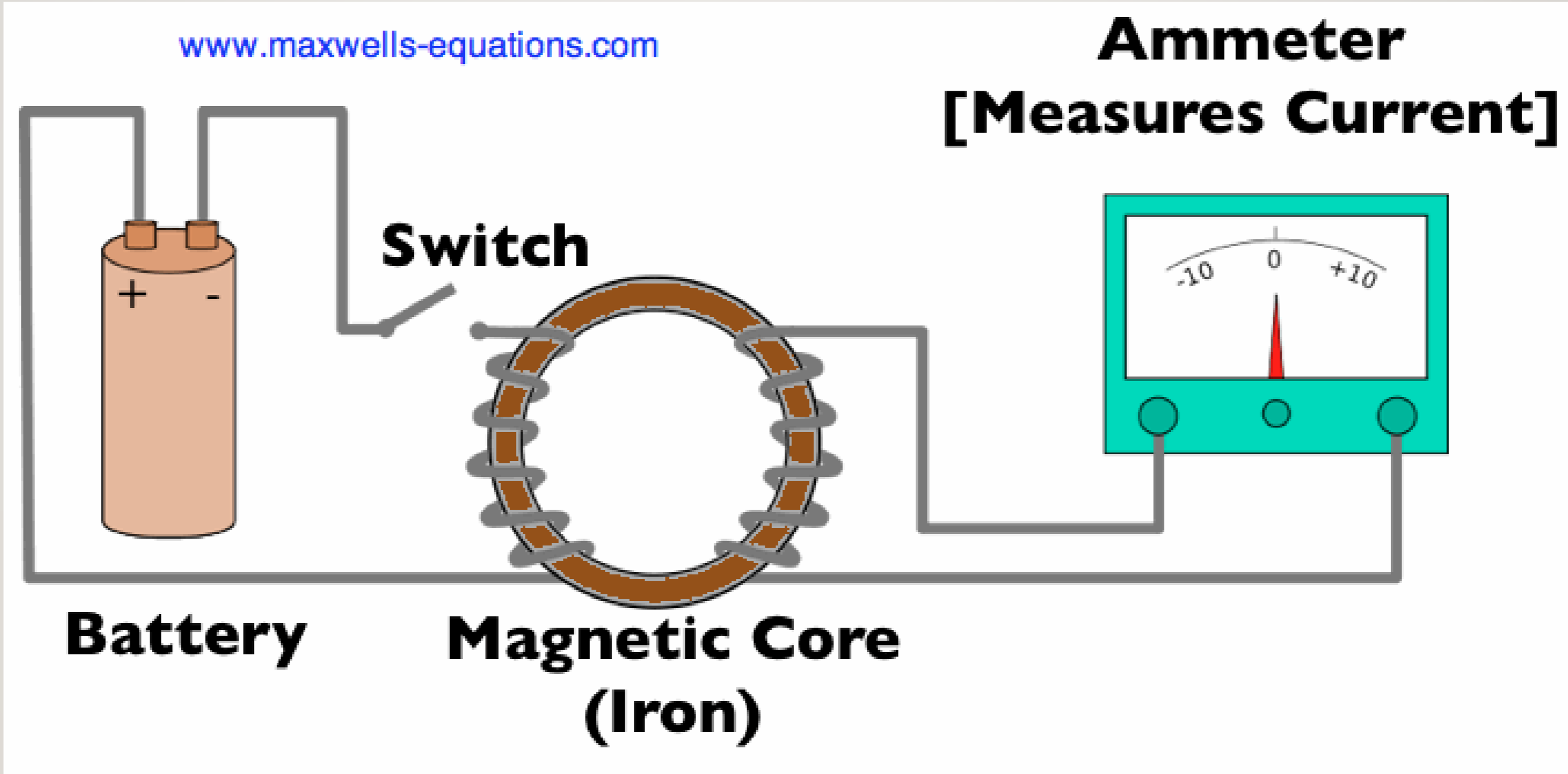

# HIPOTESIS MAXWELL

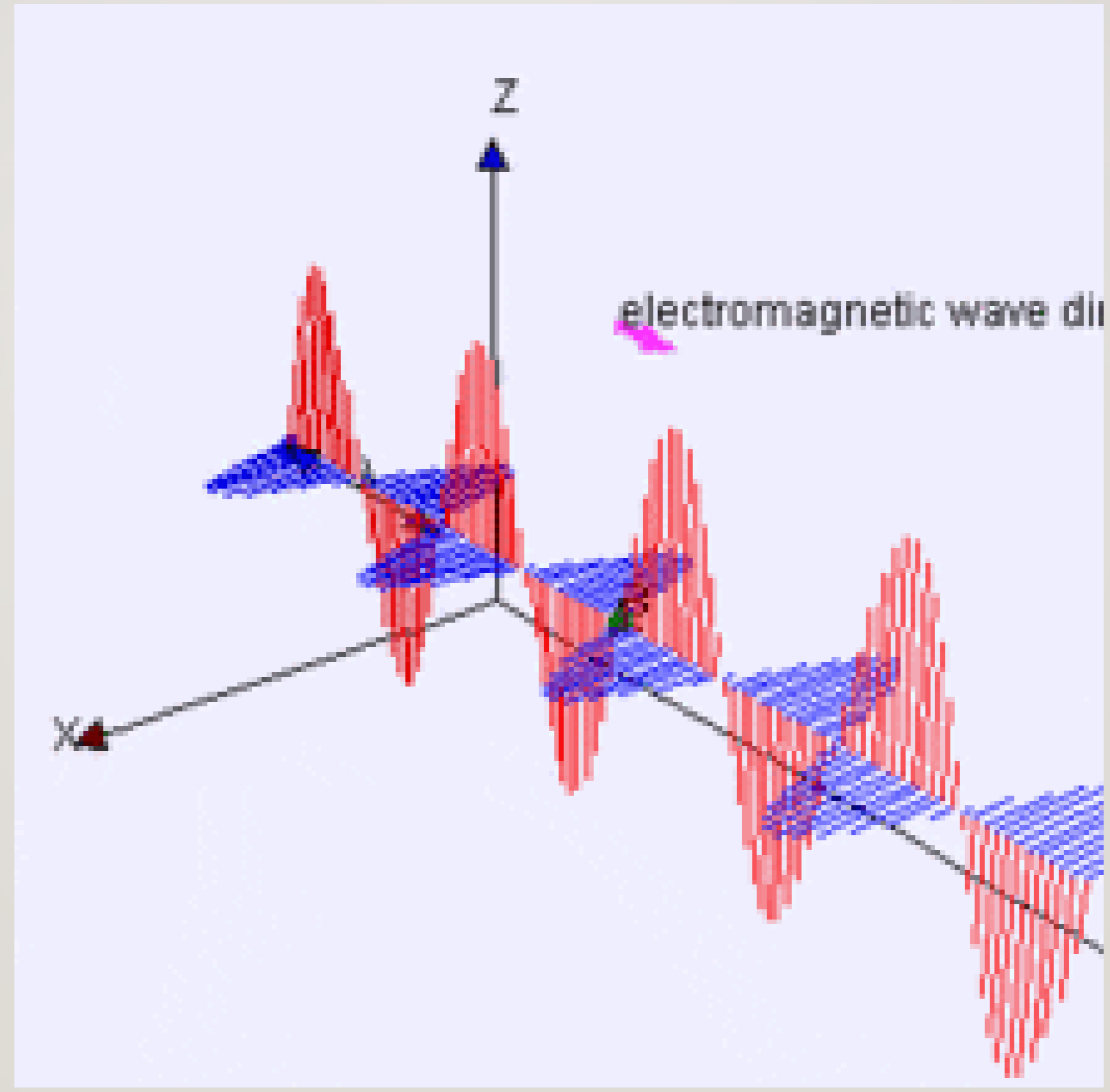

# HERTZ EXPERIMENT

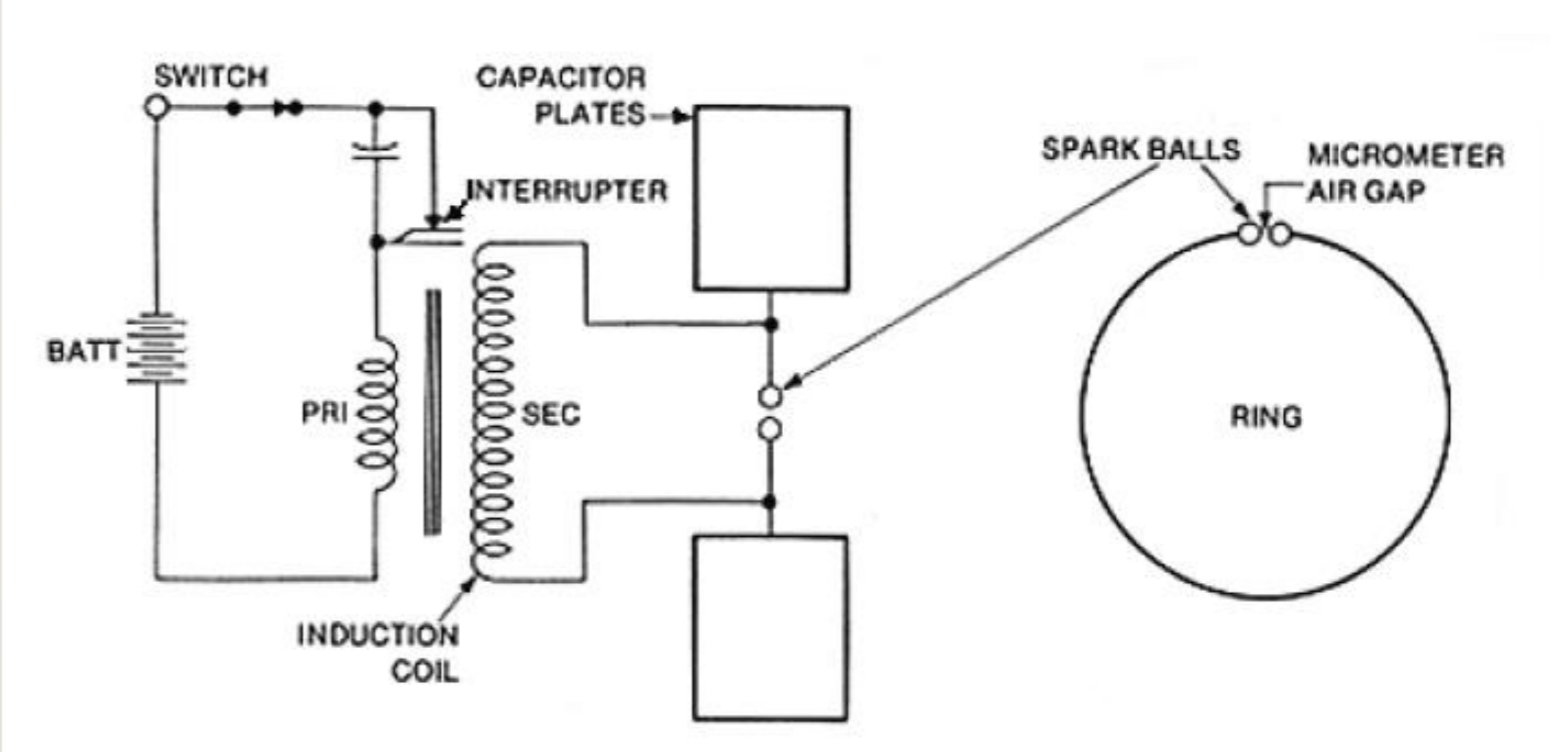
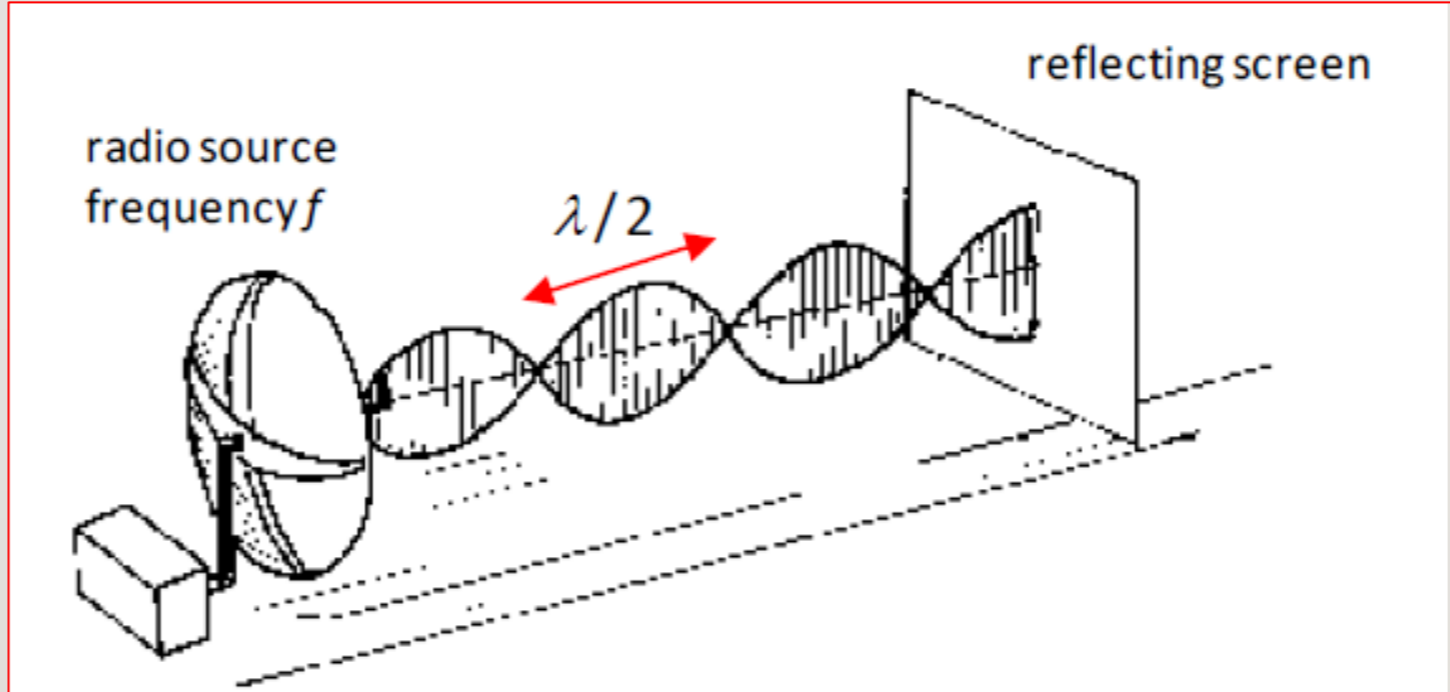
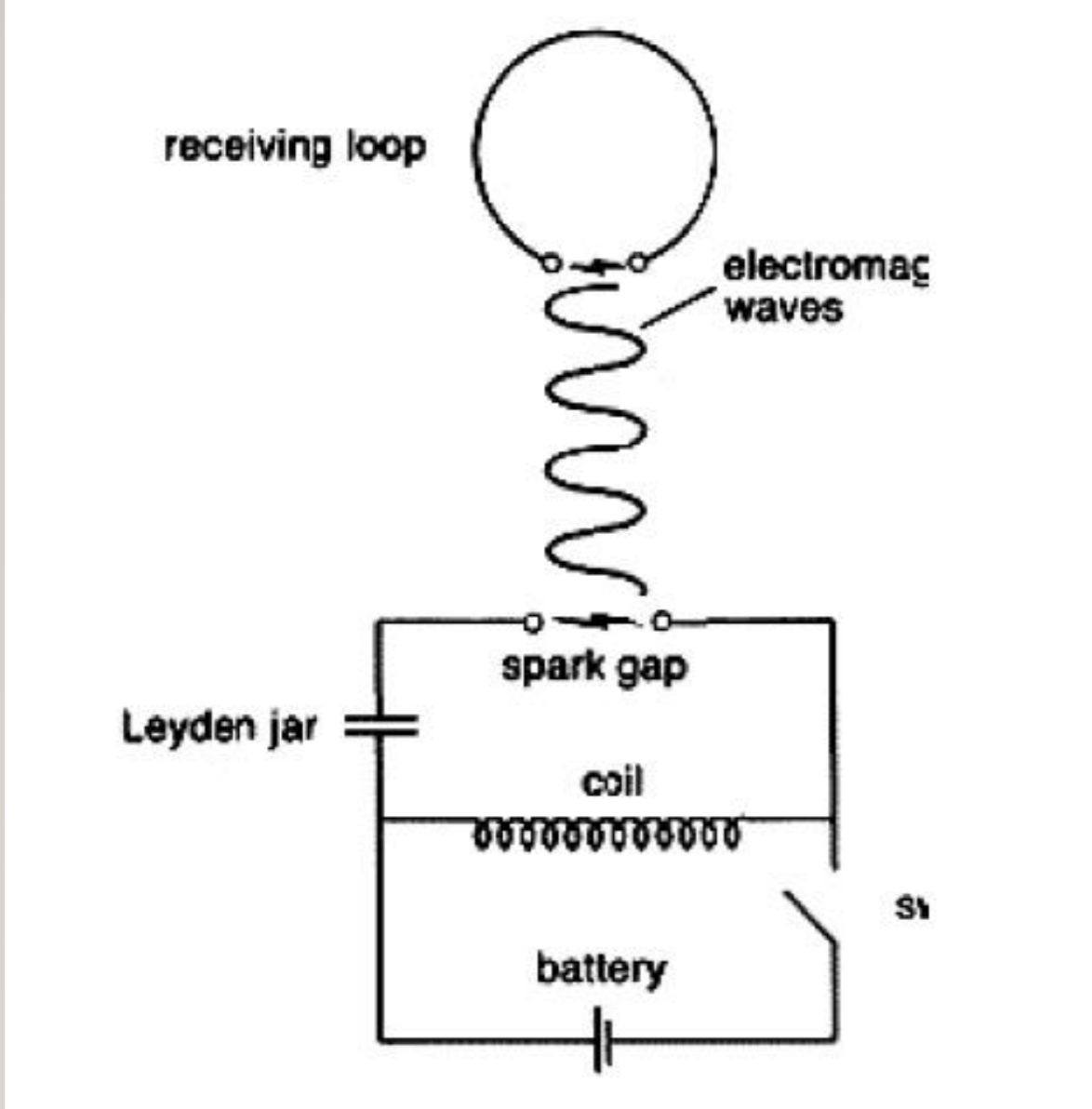

# SPEKTRUM GELOMBANG ELEKTROMAGNETIK

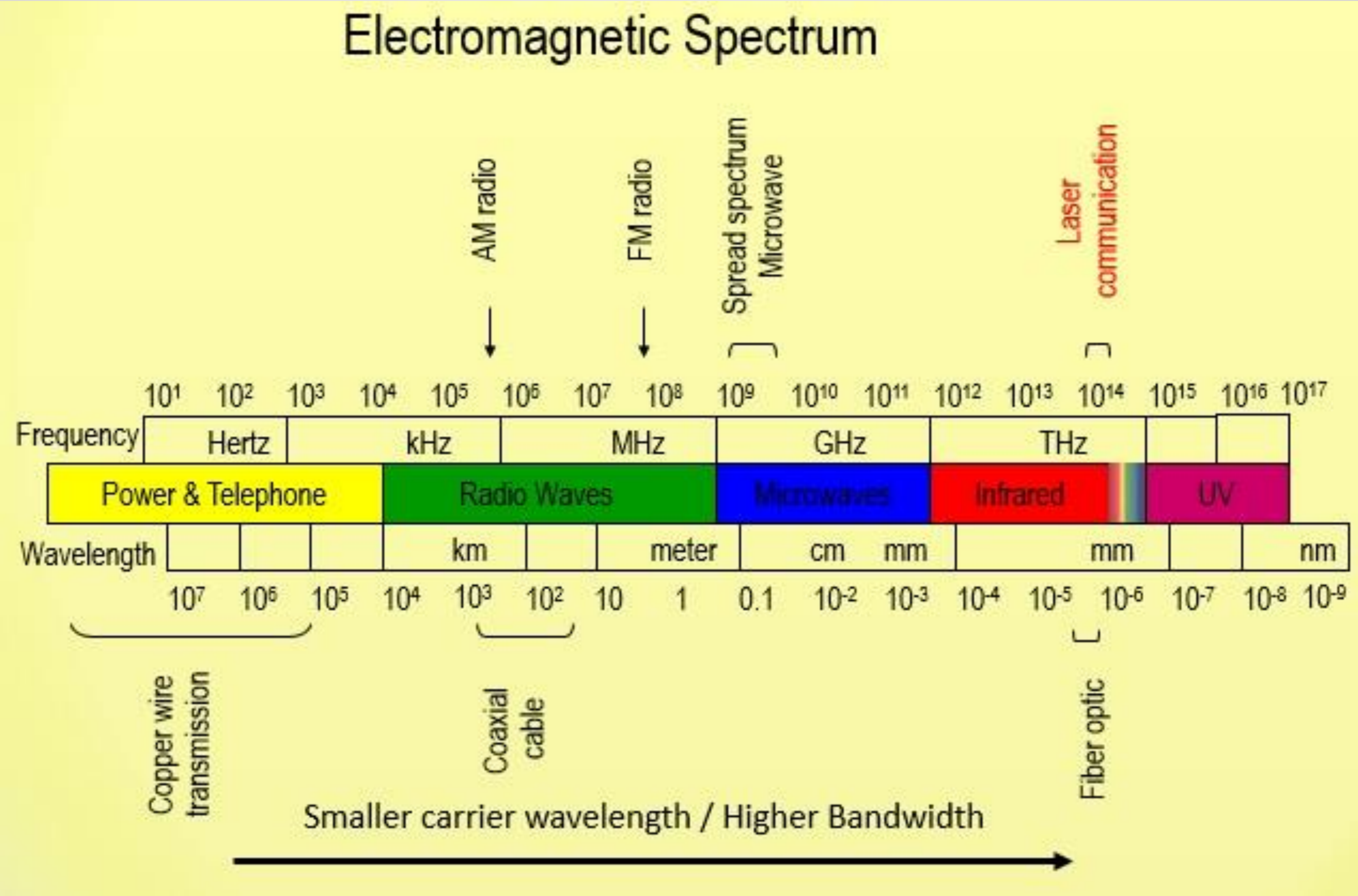

# SPEKTRUM OPTIK

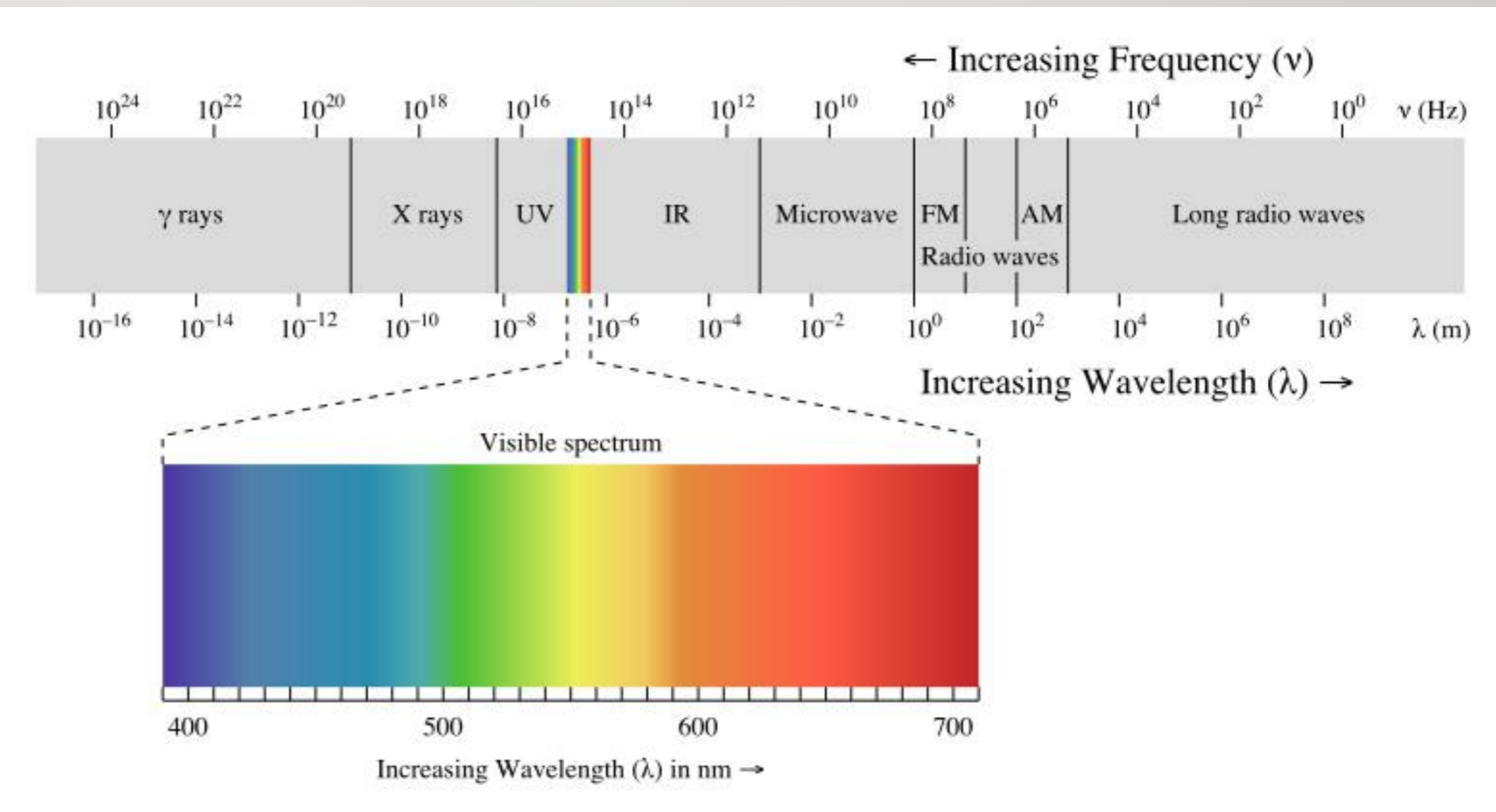
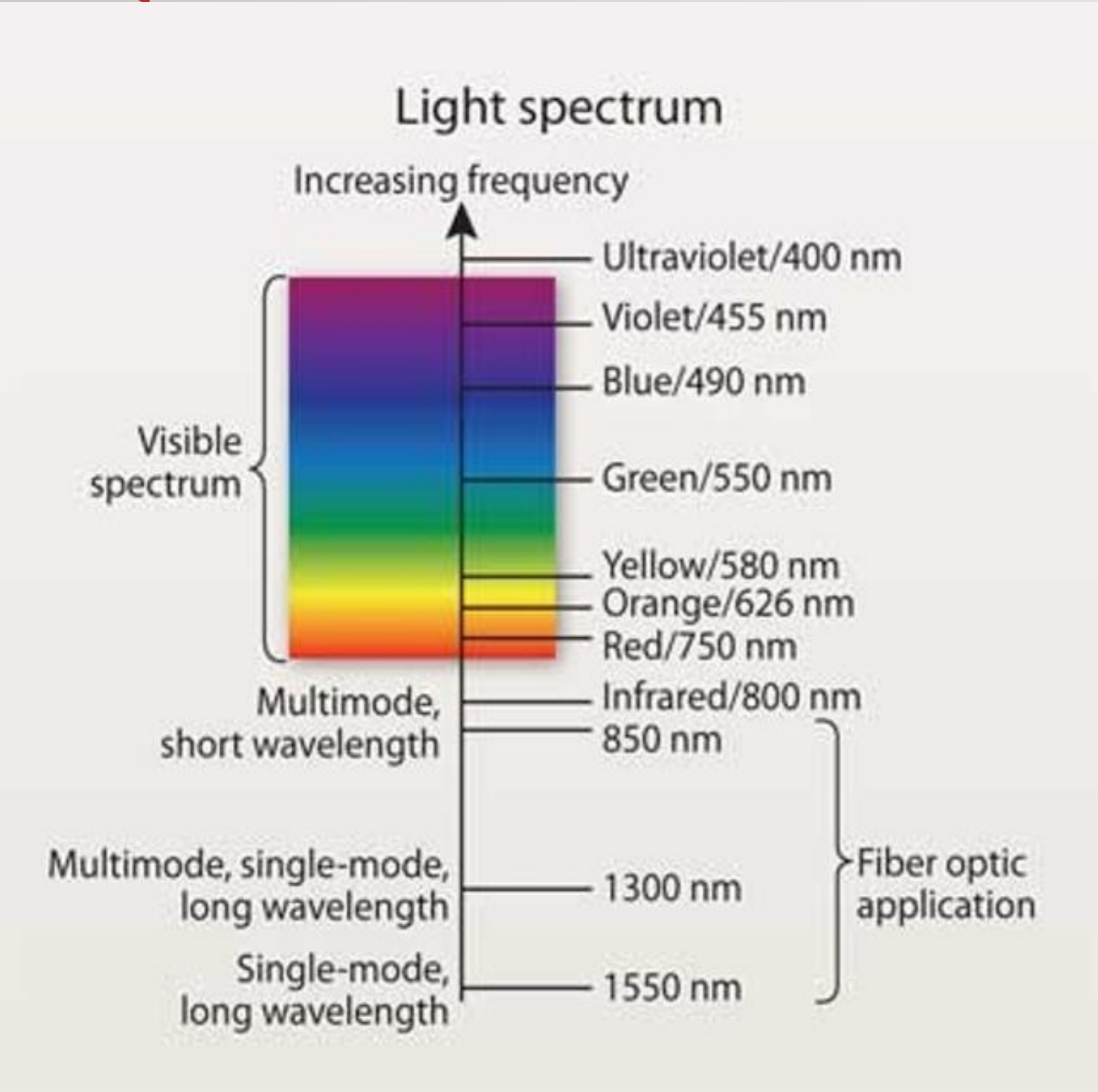

Panjang Gelombang Visible Light (nm)	Warna
400 - 440 nm	Violet
440 - 480 nm	Biru
480 - 560 nm	Hijau
560 - 590 nm	Kuning
690 - 630 nm	Oranye
630 - 700 nm	Merah

**Optik adalah gelombang elektromagnetik dengan frekuensi yang tinggi [ordenya 10<sup>14</sup> Hz]**



# TERIMA KASIH



## UNITED STATES OFFICE

1243 Barker Cypress  
San Francisco, California



## EUROPE OFFICE

13 Ave. Ballarta  
Barcelona, Spain



## SOUTH AMERICA OFFICE

45 Calle Norte  
Argentina